

St. JOSEPH'S COLLEGE OF ENGINEERING

(An Autonomous Institution)

REGULATIONS 2025

CHOICE BASED CREDIT SYSTEM

Common to all B.E. / B.Tech. Full-Time Programmes

(For the students admitted to B.E. / B.Tech. Programme from the Academic year 2025- 2026 onwards)

1. DEFINITIONS AND NOMENCLATURE

In this Regulation, unless the context otherwise specifies:

- i. **“Programme”** means Degree Programme (i.e) B.E. / B.Tech. Degree Programme.
- ii. **“Discipline”** means discipline of B.E. / B.Tech. Degree Programme, like Mechanical Engineering, Biotechnology, etc.,
- iii. **“Course”** means a Theory or Practical subject that is normally studied in a semester, like Mathematics, Physics, Engineering Graphics, etc.,
- iv. **“Controller of Examinations”** means the Authority of the Institution who is responsible for all Examinations related activities of the Institution.
- v. **“Head of the Institution”** means the Principal of the Institution.
- vi. **“Head of the Department”** means Head of the Department concerned.
- vii. **“Dean-Academics”** means the authority of the Institution who is responsible for all the activities in connection with academic regulations, curricula, syllabi & academic schedule for all the academic programs and other academic activities, from time-to-time.
- viii. **“College”** means St. Joseph's College of Engineering, Chennai.
- ix. **“University”** means Anna University, Chennai.

2. ADMISSION PROCEDURE

2.1. Admission to First Semester

- i. Students for admission to the first semester of the eight semesters B.E./B.Tech. Degree Programme shall be required to have a pass in Higher Secondary Examination (Academic 10 + 2) Curriculum or its equivalent examinations with Mathematics, Physics and Chemistry/any other subjects accepted by the Directorate of Technical Education, Tamil Nadu and the affiliating University.

(OR)

- ii. Shall be required to have a pass in Higher Secondary Examination of Vocational Stream (Vocational groups in Engineering / Technology) as prescribed by the Directorate of Technical Education, Tamil Nadu and the affiliating University.

2.2. Lateral Entry Admission

- i. Candidates who possess Diploma in Engineering / Technology awarded by the State Board of Technical Education, Tamil Nadu or its equivalent are eligible to apply for Lateral entry admission to the third semester of B.E. / B.Tech. Programme corresponding to the branch of study.

(OR)

- iii. The candidates who possess the Degree in Science (B.Sc.) (10+2+3 stream) with mathematics as a course at the B.Sc. level are eligible to apply for admission to the third semester of B.E. / B.Tech. Such candidates shall undergo two additional engineering courses in the third and fourth semesters as prescribed by the academic council of the institution.

3. PROGRAMMES OFFERED

- A student may be offered admission to any one of the programme of study approved by the University. The recommended credit range for each programme is 160 –170, preferably around 165.

Table 1 - List of Programmes offered

S.No.	Programme	Programme code
B. E. Programmes		
1.	B.E. - Computer Science and Engineering	CS
2.	B.E. - Computer Science and Engineering (Cyber Security)	CC
3.	B.E. - Electronics and Communication Engineering	EC
4.	B.E.- Electrical and Electronics Engineering	EE
5.	B.E. - Mechanical Engineering	ME
6.	B.E. - Mechatronics Engineering	MZ
7.	B.E. - Computer Science and Business Systems	CB
B. Tech. Programmes		
8.	B.Tech.- Artificial Intelligence and Data Science	AD
9.	B.Tech.- Artificial Intelligence and Machine Learning	AL
10.	B.Tech. - Biotechnology	BT

11.	B.Tech. - Chemical Engineering	CH
12.	B.Tech. - Information Technology	IT

- Students who join a B.E./B.Tech. programmes, apart from this regular programme, if they wish, they have a choice to take up any one of the following two degree programmes, from the V semester onwards, provided they satisfy certain criteria as mentioned in clause 4.12.

4. STRUCTURE OF THE PROGRAMMES

4.1. Categorization of Courses

Every B.E. / B. Tech. Programme will have a curriculum with syllabi consisting of theory and practical courses that shall be categorized as follows:

- i. **Engineering Science Courses (ESC)** include courses such as Mathematics, Physics, Chemistry, Biology, etc.
- ii. **Humanities and Social Sciences including Management Courses (HSMC)** include English, Employability Skills, Engineering Ethics and Management courses.
- iii. **Program Core Courses (PCC)** include the core courses relevant to the chosen specialization/branch.
- iv. **Program Elective Courses (PEC)** are the courses which can be chosen from a larger pool of courses and are very specific / specialized / advanced / supportive to the discipline which nurtures the students' proficiency in the discipline.
- v. **Open Elective Courses (OEC)** include interdisciplinary courses which are offered in other Engineering/Technology Programme of study.
- vi. **Ability Enhancement Course**
 - a) **Skill Development Courses (SDC)** are the courses offered to enhance specific abilities and competencies of the students in academic and professional contexts.
 - b) **Self-Learning Course (SLC)** is a course to be selected by the students allowing them to interact with global network of faculty, peers, and industry experts from anywhere in the world, that facilitates developing an aptitude for life-long learning.
 - c) **Value Added Courses (VAC)** are the courses not prescribed in the respective curriculum, that are offered to the students to provide additional value to the student's education for enhancing the knowledge and skills.
- vii. **Industry Oriented Courses (IOC)** are offered to allow students to expand their knowledge and skills in specific areas and meet the ever-changing needs of the various industrial sectors.
- viii. **Mandatory courses (MC)** include Personality and Character development and the courses recommended by the regulatory bodies such as AICTE, UGC, Anna University etc.

- ix. **Audit Courses (AC)** expose the students to Environmental Sciences, Unnat Bharath Abhiyan, Constitution of India, Essence of Indian Knowledge Traditional, Yoga, English for Research Paper Writing, Value education, Pedagogy Studies, Stress Management and Personality Development through Life Enlightenment Skills. Registration for any of these courses is optional to students.

4.1.1 Mandatory Personality and Character Development Programme

- **All students shall enroll on admission in any one of the personality development programmes** such as club activities like Mathematics Club, English Club, Tamil Club, Science Club etc., combined with character building / Service oriented activities such as NCC/NSS/NSO/YRC etc., for a total period of 80 hours and attend a camp of about seven days. The training shall include classes on hygiene, Women self-esteem, self-defense and health awareness and also training in first-aid.
- **National Cadet Corps (NCC)** will have about 20 parades.
- **National Service Scheme (NSS)** will have social service activities in and around the College / Institution. The activities will include hygiene and practical projects on recycling and reusing biodegradable and dry waste.
- **National Sports Organization (NSO)** will have sports, games, drills and physical exercises.
- **Youth Red Cross (YRC)** will have activities related to social services in and around College/Institutions. While the training activities will normally be during weekends, the camp will normally be during vacation period.

4.1.2 Mandatory Two-Week Induction Programme

The students are expected to undergo a mandatory two-week induction programme comprising of physical activity, creative arts, universal human values, proficiency modules, lectures by eminent people, visits to local areas and familiarization to department/branch & innovations immediately after admission as per UGC/AICTE guidelines.

4.2. Number of Courses per semester

The Curriculum of each semester shall normally have a blend of theory courses and theory cum practical courses not exceeding 7 and Practical courses not exceeding 4. However, the total number of courses per semester shall not exceed 10. Each course may have credits assigned as per clause 4.3.

4.3. Credit Assignment

Each course is assigned with credits with respect to contact periods as given in Table 2.

Table 2 – Credits for Contact Period(s)

Contact Period	Credits
1 Lecture Hour	1
1 Tutorial Hour	1
1 Laboratory Hour	0.5

- i. ONE credit is assigned to ‘Industrial training/ Internship’ for every ‘TWO WEEKS’ duration.
- ii. ONE credit is assigned to ‘SWAYAM / NPTEL courses for every ‘FOUR WEEKS’ duration.

4.4. Course Code

Each course offered by a department under Program Core Courses category is assigned with a course code consisting of two alphabets, followed by five numerals. First two alphabets denote the code of the Programme. First two numerals denote the code of the Regulation. Third numeral denotes ‘Semester’ and last two numerals denotes the unique identification number of the course.

- For example, in B.E., Mechanical Engineering programme, a particular PCC offered in the first semester is denoted as

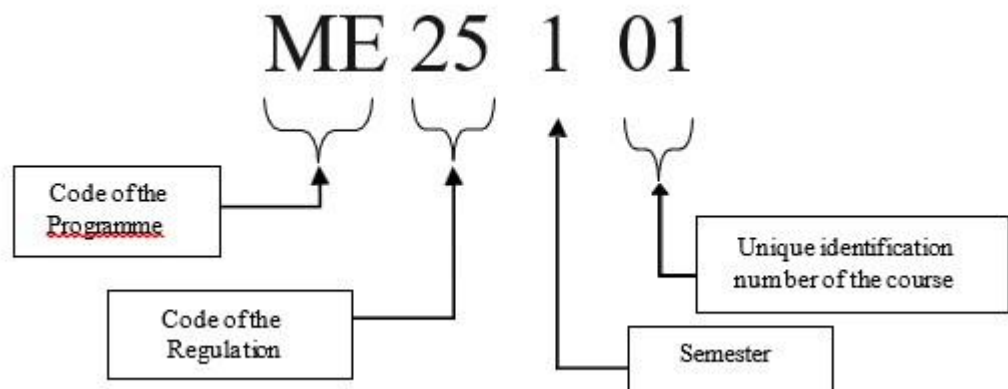

- For Program Elective Courses offered by the Department, course codes are assigned as follows.

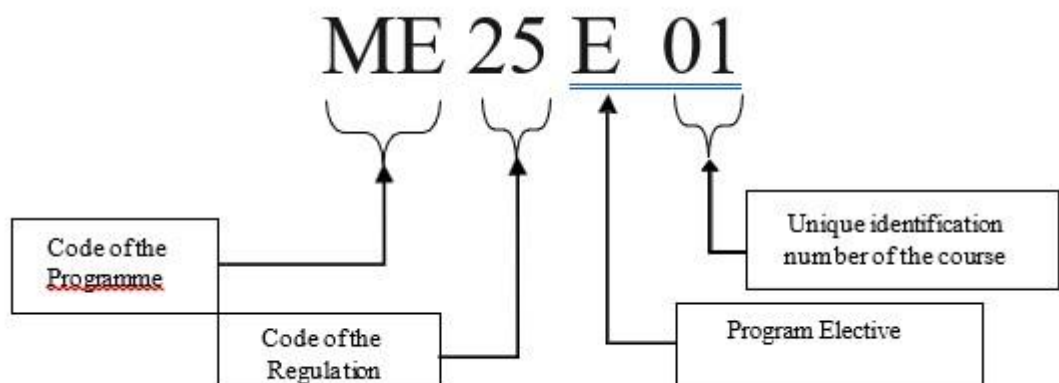

- For Open Elective Courses, course codes are assigned as follows.

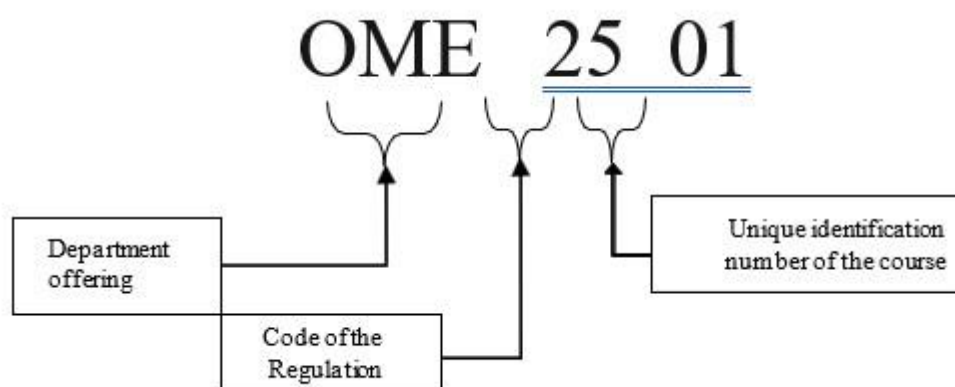

- For common courses offered by the Department, the third numeral denoting ‘Semester’ is designated as ‘C’.

For Example, English Department, a particular common course is denoted by

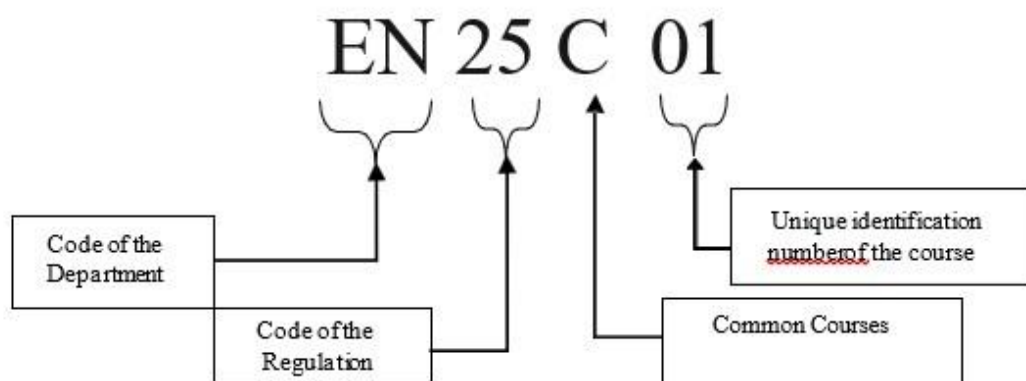

- Similarly, MA – Mathematics, PH – Physics, CY – Chemistry GE – Tamil, AC – Audit courses, SD – Aptitude Training, Communication skill Enhancement, soft skill training, Placement oriented Training courses etc., SL- Self Learning Courses

Table 3 – Designation of Course Categories

S.No.	Course	Designated as
1.	Program Core Courses	‘Semester’ [Ex:1,2,3,4,5,6,7,8]
2.	Program Elective Courses	E
3.	Common courses	C
4.	Industry Oriented Courses	I
5.	Value Added Course	V
6.	Mini Project, Department specific skill development courses	S
7.	Seminar	L
6.	Online Course	N

4.5. Industrial Visit

Every student is required to go for at least one Industrial Visit every year, (Except VIII Semester), starting from the second year of the Programme. The Heads of Departments shall ensure that necessary arrangements are made in this regard.

4.6. Internship

The students may undergo Internship for a period as specified in the Curriculum during the summer / winter vacation. The students may undergo Internship at a Research organization / University / industry (after due approval from the Heads of the Departments) continuously for the entire period. If Internship is not prescribed in the curriculum, the student may undergo Internship optionally and the credits earned through the Internship shall be over and above the total credit requirement for the award of the degree.

Table 4 – Credit transfer for Internship

Duration of Internship	Credits
2 Weeks	1
4 Weeks	2

4.7. Industry Oriented Courses

- i. There shall be ‘TWO’ Industry Oriented Course (IOC) to be successfully completed by student, as prescribed in the respective curriculum. Students shall also be permitted to register for these courses offered by other departments, provided the student has fulfilled the necessary pre-requisites of the course being offered.
- ii. Proposal for conduct of IOC shall be submitted by the respective department to the Head of the Institution during the commencement of each semester for conducting IOC(s) in the subsequent semester, as per the curriculum.
- iii. Course content of IOC shall be framed by the identified industrial expert in consultation with the department concerned. A faculty member shall be nominated as coordinator by the respective Department. Content shall be of trans / multidisciplinary in nature, with practical applications such as case studies, standards, certifications, etc.
- iv. The proposal shall contain a brief introduction about the expert, title of the course, lesson plan for 15 hours, tentative schedule of the classes and pre-requisite(s), if any, for the students to undergo the IOC.
- v. The received proposals shall be placed before the Department Advisory Committee (DAC) by the Head of the Department and with recommendations of DAC, proposal(s) shall be forwarded, within 15 days before the last working day of the ongoing semester to the Controller of Examinations for further action. List of approved IOCs shall be widely published among the students through the website and other official media of the

Institution, before the last examination date of the ongoing semester. Approved IOCs shall be offered in the subsequent semester.

- vi. Classes shall be conducted by the industry expert through physical / hybrid mode and slot for these courses shall be allotted depending on the availability of the expert in regular timetable, before or after the working hours. However, time slots on Saturdays may also be judiciously decided by the respective Head of the Institution, depending on the convenience of the students and expert. For all sessions, the coordinator shall attend the classes along with the students. Attendance register for IOC shall be maintained by the Coordinator.
- vii. Size of the batch shall be preferably below 75 for both physical and hybrid mode.
- viii. Classes for IOC shall be held in the Institute premises and the practical classes or case studies / project, if any shall be conducted at the Institute / Industry, which shall be decided by the Industry Expert in consultation with the Coordinator.
- ix. At the end of each IOC, students' feedback shall be obtained and reviewed by the respective Head of the Department, for further refinement of the course.

4.8. Value Added Courses

Students may optionally undergo value added courses and the credit earned through the value-added courses shall be over and above the total credit requirement prescribed in the curriculum for the award of the degree. The Head of the Department can form a committee, a team of senior faculty members (preferably three) to recommend the list of value-added courses. One/two credit courses shall be offered by a department with prior approval from the committee. The details of the syllabus, timetable and faculty may be sent to the controller of examinations after approval from the Head of the Department. Students can take a maximum of two 'one credit courses' or one 'two credit course'.

4.9. Online Courses

Students are permitted to optionally enroll and study a maximum of one online course in each semester starting from III semester till VII semester. Department Advisory Committee (DAC) shall approve the online courses towards attaining Industrial Employability and fulfilling the Curriculum Gap.

4.8.2 Students are permitted to optionally enroll and study these courses through SWAYAM / NPTEL platforms and credit transfer is to be done based on the marks and certificate provided by the NPTEL. The number of credits and transfer of credits are based on the procedure explained in Table 1, grades shall be assigned based on Table 2. The mapping of marks with grades is applicable only if the student passes the course as per the guidelines of NPTEL.

Table 5 - Duration of the course and Number of credits

Sl. No.	No. of Weeks	No. of Credits
1.	4	1
2.	8	2
3.	12	3
4.	16	4

Table 6 - Mapping of Marks scored in NPTEL course and Credits earned

Letter Grades	Marks
O	88-100
A+	76-87
A	64-75
B+	52-63
B	40-51

4.10. Audit courses

The student may study audit courses prescribed in the curriculum, and it will be mentioned in the Grade Sheet. However, it will not be considered for computation of CGPA.

4.11. Medium of Instruction

The medium of instruction is English for all courses, examinations, seminar presentations and project/thesis/dissertations reports.

4.12. B.E. / B. Tech. (Honours) and B.E. / B. Tech. minor with specialisation in another discipline.**4.12.1. Honours Degree**

Students always have a passion or fascination for a particular field or a line of thinking or study, and Honours Degree option enables the student to nurture this interest. Students shall obtain Honours degree by successful completion of additional courses in the 'FIRST APPEARANCE' itself. These additional courses are over and above the courses prescribed in the respective curriculum from 'FIFTH' semester onwards. Additional courses shall be either a 'CAPSTONE DESIGN PROJECT' or 'SIX ELECTIVE COURSES'.

- (i). Students shall earn 'EIGHTEEN' credits and split up of credits shall be given in the respective curriculum.
- (ii). Eligibility for any student admitted under Clause 4.1 of this regulation to opt for the Honours degree is that the student should earn a minimum CGPA of 7.0 in 'THIRD' and 'FOURTH' semesters together and students should not have any history of arrears from first semester.

- (iii). Eligibility for any student admitted under Clause 4.2 & Clause 4.3 of this regulation to opt for the Honours degree is that the student should earn a minimum CGPA of 7.0 in 'THIRD' and 'FOURTH' semesters together without any backlog arrears in Third and Fourth semesters.

4.12.2. Capstone Design Project for 'HONOURS' Degree

- (i). Capstone Design project provides an opportunity to work in a team to design and develop a product, focusing to evolve solutions for real-time problems, starting from Problem definition, Specification formulation within given constraints, Review of design process and design ideation, Human factors, Market research, Product and patent research, fabrication considerations, Safety and risk assessment, Liability and
- (ii). ethics, Environmental and sustainability considerations, Proof-of-concept methods, Codes and Standards, etc. and finally to test prototype(s).
- (iii). A group comprising of 4 to 6 students, spread over minimum of two departments and maximum of three departments, shall opt for Capstone Design Project in 'THREE PHASES' from V to VII semester, in addition to the courses as prescribed in the curriculum. It is mandatory that students from at least TWO departments shall be a part of the project group and the number of students from each department shall be at least TWO.
- (iv). A Mentor shall be identified by the students from any one of the participating Department. Head of the Department of the Mentor's Department with approval of the Head of the Institution, shall constitute a Project Review Committee (PRC) consisting of Mentor, one faculty – from the department of the students (other than the Mentor's Department) in the group and one expert from industry in the relevant field. Student shall also identify Co-Mentor(s) from the participating department(s).
- (v). During the Capstone Design Project, the student groups are encouraged to participate in events such as Hackathon, Industrial Expo to showcase and pitch their inventions.
- (vi). Evaluation of Capstone Design Project is by continuous assessment (Three periodical reviews) in each semester by the PRC and Viva-voce examination at the end of each semester. Viva-Voce examination shall be conducted with panel of Internal examiners (PRC) and ONE external examiner. Weightage for Continuous assessment is 60% and for project report evaluation along with Viva-voce examination is 40%.
- (vii). Every student in the group shall secure a minimum 45% of marks in Project report evaluation & viva-voce examination and also obtain a 50% of total marks in the Continuous assessments + (Project report evaluation & viva-voce examination)

for getting 'PASS' in the particular phase of Capstone Design Project. Upon successful completion of the particular phase, the students shall be allowed to proceed to the next phase. In case, if any student in the group is not able to secure 'PASS' as prescribed above, the student shall discontinue from the Capstone Design Project and shall not associate with the Capstone Design Project furthermore.

- (viii). After earning 'EIGHTEEN' credits through the successful completion of the Capstone Design Project (CDP), 'HONOURS' shall be conferred along with 'Certificate of Appreciation' to the students, who secure 8.50 or higher CGPA, without any history of arrears. If the student in the group, after successful completion of Capstone Design Project secures less than 8.50 CGPA, 'HONOURS' degree shall not be conferred. However, the result of Capstone Design Project shall feature in the Grade sheet, and a 'Certificate of Appreciation' shall be issued to those students.

4.12.3. Six Elective Courses for 'HONOURS' Degree

- a) Students shall opt for 'Honours' Degree by undergoing 'SIX' additional course works from the Honours vertical or courses from existing verticals as listed in the respective curriculum. The student has to earn 18 additional credits through the course works, which are related to the major discipline of study. Evaluation and 'PASS' requirement of these courses is as per Clause 11.1 & 11.2 for Theory & Laboratory Integrated Theory courses respectively.
- b) Eligibility for any student to opt for the Honours degree is that the student should earn a minimum CGPA of 7.0 in third and fourth semesters and students should not have any history of arrears from first semester.
- c) On successful completion of six course works, HONOURS' will be conferred to the students, who secure a CGPA of 7.5 or higher, without any history of arrears.
- d) If the student decides to opt out of Honours Degree, after successful completion of certain number of course work(s), these course(s) shall be treated as equivalent to PEC(s). In such case, the student shall be permitted to drop the equal number of PEC(s).
- e) If the student successfully completes more number of PEC over and above the SIX mandatory courses, the courses with higher grades shall be considered for the calculation of CGPA. Remaining courses shall be only printed in the grade sheet and grade obtained in these courses shall not be considered for computation of CGPA.

4.12.4. Minor Degree

- a) A student can enroll for 'Minor' from the fifth semester by registering course works as prescribed in the curriculum of the UG Programme offered by the

department other than the parent department of the student. Evaluation and 'PASS' requirement of these courses is as per Clause 10.1 & 10.2 for Theory & Laboratory Integrated Theory courses respectively.

- b)** Eligibility for any student to opt for the Minor degree is that the student should earn a minimum CGPA of 7.0 in third and fourth semesters and also students should not have any history of arrears from first semester.
- c)** In order to get Minor Degree, a student has to successfully complete the basket of courses as prescribed in the curriculum of the Department offering the Minor Degree and earn 18 extra credits.
- d)** If the student decides to opt out of Minor Degree, after successful completion of certain number of course(s), these course(s) can be treated as equivalent to OEC(s). In such case, the student shall be permitted to drop the equal number of OEC(s).
- e)** If the student successfully completes more number of OECs over and above the courses prescribed in the curriculum, the courses with higher grades shall be considered for the computation of CGPA. Remaining courses shall be only printed in the grade sheet and grade obtained in these courses shall not be considered for computation of CGPA.
- f)** Minor Degree shall be reflected in the degree certificate as "B. E., / B. Tech., in XYZ Engineering with Minor in ABC", where 'XYZ' is the Major Discipline of study and 'ABC' is the Discipline in which Minor Degree is offered.
- g)** If the student has failed in the additional courses or faced shortage of attendance, they will not be printed in the grade sheet and will not be considered for CGPA calculation and classification of degree.
- h)** The student has to enroll for these additional courses separately and pay a tuition fee for studying these six additional courses and pay additional exam fee. If the student has studied more number of such courses than the number of open electives required as per the curriculum, the courses with higher grades shall be considered for calculation of CGPA. Remaining courses shall be printed in the grade sheet, however, they will not be considered for calculation of CGPA and the same shall be indicated in a foot note appropriately. If the student has failed in the additional courses or faced shortage of attendance, they will not be printed in the grade sheet and will not be considered for CGPA calculation and classification of degree. The student has to enroll for these additional courses separately and pay a tuition fee for studying these six additional courses and pay additional exam fee.

5. DURATION OF THE PROGRAMMES

5.1. The minimum and maximum periods for completion of the UG programmes are given below

Table 6 – Duration of Programmes

Programme	Minimum No. of semesters	Maximum No. of semesters
B.E./ B.Tech.	8	14
B.E./ B.Tech. Lateral Entry	6	12

Each semester normally consists of 90 working days. In any contingent situation, the number of working days per semester shall not be less than 75 days. The Head of the Institution is given the discretionary powers to decide the number of working days in such contingencies. The Head of the Institution shall ensure that every teacher imparts instruction as per the number of periods specified in the syllabus and that the teacher teaches the full content of the specified syllabus for the course being taught. For regulations, the academic year has been divided into two semesters, the Odd semester normally spanning from July to November and the even semester from January to May.

The First semester of B.E. / B.Tech. Degree Programme normally spans from August to December and Second semester from January to May. The total duration for completion of the programme reckoned from the commencement of the first semester to which the student was admitted shall not exceed the maximum duration specified in clause 5.1, irrespective of the period of break of study (**vide clause 18**) or prevention (**vide clause 7.4**), in order that the student may be eligible for the award of the degree (**vide clause 14**).

6. COURSE REGISTRATION

- i.** Each student on regular admission has to register for all the courses prescribed in the first year of study.
- ii.** A student has to earn the minimum number of total credits specified in the curriculum of the chosen programme of study in order to be eligible to obtain the degree. However, a student can earn more than the minimum number of credits, if he/she wish. In such cases, the minimum number of credits required for the completion of the programme alone would be considered for CGPA calculation.
- iii.** The registration for the courses of the semesters III to VIII will commence 10 working days prior to the commencement of classes of the current semester. The student shall register for the courses with the guidance of his faculty mentor. The student may also drop courses (**vide clause 6.1**) within 5 working days of the commencement of the concerned semester and complete the registration process.
- iv.** For an elective to be offered, number of students registered for an elective should be minimum of 10.

- v. After registering for a course, a student should attend classes, satisfy attendance requirements (**vide clause 7**), earn continuous assessment and appear for the End Semester Examinations.

6.1. Flexibility to add or Drop courses

A student has to earn the total number of credits specified in the curriculum of the respective programme of study in order to be eligible to obtain the degree. However, If the student wishes, then the student is permitted to earn more than the total number of credits prescribed in the curriculum of the student's programme within the minimum duration of the programme. From the III to VIII semesters, the student has the option of registering for additional courses or dropping existing courses. The total number of credits that a student can add or drop is limited to 8, subject to a maximum of 2 courses. The student shall register Project work in VIII Semester. A student can earn a maximum of 2 one- credit courses per semester.

6.2. Redoing a Course

Redoing a course means reregistering for a course, attending all classes, fulfilling the attendance requirements as per clause 7, earning fresh Continuous Assessment marks and appearing for End Semester Examinations. A student has to redo a course in the following conditions.

- 6.2.1.** If a student is prevented from writing end semester examination of any core course due to lack of attendance, the student has to register for that course again when offered next and redo the course.
- 6.2.2.** If a student is prevented from writing the end semester examination of any professional/open elective course due to lack of attendance, the student can opt to register for the same course again when offered next and redo the course, or he/she can opt to register for a different professional/open elective course when it is offered, attend classes, fulfill the attendance requirements as per clause 7, secure Continuous Assessment marks and appear for End Semester Examinations.
- 6.2.3.** If a student fails to secure a pass in any theory or Laboratory course (including elective theory), The internal assessment marks obtained by the student in the first appearance shall be retained and considered valid for all subsequent attempts till the student secures a pass. However, from the third attempt onwards if a student fails to obtain pass marks (IA + End Semester Examination) as per clause 11.1, then the student shall be declared to have passed the examination if he/she secures a minimum of 50% marks prescribed for the end semester examinations alone.
- 6.2.4.** If the course in which the student fails to secure a pass even after three arrear attempts is a professional/open elective course, then the student can opt for a different professional/ open elective course, register for the same when it is offered, attend

classes, fulfill the attendance requirements as per clause 7, secure Continuous Assessment marks and appear for End Semester Examinations.

6.2.5. The student who fails in Project work shall register for the course again, when offered next, and redo the course. In this case, the student shall attend the reviews and fulfill the attendance requirements as per clause 7.

6.2.6. The student who fails in Seminar / Internship / Case Study and Creative and Innovative project shall register for the same in the subsequent semester and redo the course. In this case, the student shall attend the classes and fulfill the attendance requirements as per **clause 7**.

7. REQUIREMENTS FOR APPEARING FOR THE END SEMESTER EXAMINATION OF A COURSE

A student who has fulfilled the following conditions (vide clause 7.1 and 7.2) shall be deemed to have satisfied the attendance requirements for appearing for the end semester examination of a particular course.

7.1. Ideally every student is expected to attend all periods and earn 100% attendance. However, the student shall secure not less than 75% attendance, course wise, taking into account the number of periods required for that course, as specified in the curriculum.

7.2. If a student secures attendance between 65% and less than 75% in any course in the current semester, due to medical reasons (hospitalization / accident / specific illness) or due to participation in the College / University / State / National / International level Sports events, with prior permission from the Principal Competent Authority and Head of the Department concerned, the student shall be given exemption from the prescribed attendance requirement and the student shall be permitted to appear for the end semester examination of that course. In all such cases, the students should submit the required documents on joining after the absence to the Head of the Department through the Faculty Advisor.

7.3. A student shall normally be permitted to appear for the end semester examination of the course if the student has satisfied the attendance requirements (vide Clause 7.1 – 7.2) and has registered for the examination in those courses of that semester by paying the prescribed fee.

7.4. Students who do not satisfy clause 7.1 and 7.2 and who secure less than 65% attendance in a course will not be permitted to write the end semester examination of that course. The student has to register and redo the course when it is offered next as per Clause 6.2. If the course in which the student has been prevented is a professional/ open elective, the student can opt to redo the same course or opt for different professional/ open elective course.

7.5. If a student has shortage of attendance in all the registered courses, he/she would not be permitted to move to the higher semester and has to repeat the current semester in the subsequent year.

7.6. In the case of reappearance (Arrear) registration for a course, the attendance requirement as mentioned in Clauses 7.1 - 7.3 is not applicable. However, the student has to register for the examination in that course by paying the prescribed fee.

7.7. A student who has already appeared for a course in a semester and passed the examination is not entitled to reappear for the same course for improvement of letter grades /marks.

8. FACULTY ADVISOR

To help the students in planning their courses of study and for general advice on the academic programme, the Head of the Department of the students will attach a certain number of students to a teacher of the Department, who shall function as Faculty Advisor for those students throughout their period of study. The Faculty Advisor shall advise the students in registering and reappearance (Arrear) registering of courses, authorize the process, monitor their attendance and progress and counsel them periodically. If necessary, the Faculty Advisor may also discuss with or inform the parents about the progress / performance of the students concerned.

The responsibilities of the faculty advisor shall be:

- To inform the students about the various facilities and activities available to enhance the student's curricular and co-curricular activities.
- To guide student enrollment and registration of the courses.
- To authorize the final registration of the courses at the beginning of each semester.
- To monitor the academic and general performance of the students including attendance and to counsel them accordingly.
- To collect and maintain the academic and co-curricular records of the students

9. COURSE COMMITTEES

9.1. Common Course Committee

A theory course handled by more than one teacher shall have a "Common Course Committee", comprising of all teachers teaching that course. One of the teachers shall be nominated as Course Coordinator by the Head of the Department concerned.

The first meeting of the Common Course Committee shall be held within fifteen days from the date of formation of the committee. The nature and weightage of the continuous assessments shall be decided in the first meeting, within the framework of the Regulations. Two or three subsequent meetings in a semester may be held at suitable intervals.

In addition the "Common Course Committee" shall meet to ensure uniform evaluation of continuous assessments after arriving at a common scheme of evaluation for the assessments **(vide clause 10)**.

Wherever feasible, the Common Course Committee shall prepare a common question paper for the continuous assessment tests also. The question paper for the end semester examination is common and shall be set by the Course Coordinator, in consultation with all the teachers.

9.2. Overall Monitoring Committee

In addition, there shall be an overall monitoring committee for each semester of a programme, which comprises of (i) the Head of the Department (convener), (ii) the Faculty Advisors of the programme and (iii) Common Course Coordinator. This overall monitoring committee shall meet

Periodically to discuss academic related matters, progress and status of the students of the semester concerned.

The overall monitoring committee can also invite some of the students for any of the committee meetings if necessary.

10. SYSTEM OF EXAMINATION AND ASSESSMENT PROCEDURE

Performance in each course of study shall be evaluated based on

- i. Continuous internal assessment throughout the semester
- ii. End Semester Examinations (ESE) at the end of the semester.

Each course, both theory / integrated and practical including project work shall be evaluated for a maximum of 100 marks.

For all the End semester examinations, wherever necessary, the internal and external examiners shall be appointed by the Controller of Examinations.

Each course shall be evaluated for a maximum of 100 marks as detailed in Table

Table 7 – Weightage for Various Course Categories

S.No	Type / Category	Continuous Internal Assessments	End-Semester Examinations
1.	Theory Courses	40 Marks	60 Marks
2.	Laboratory Integrated Theory Courses	50 Marks	50 Marks
3.	Laboratory Courses	60 Marks	40 Marks
4.	Project Work	40 Marks	60 Marks
6.	Value added Courses	100 Marks	----
7.	Self-Learning Courses	100 Marks	----
8.	Industry Oriented Courses	100 Marks	----
9.	Skill development Courses	100 Marks	----

There is no evaluation for Audit Courses. However, minimum attendance requirement as per clause 7 shall be satisfied.

Every teacher is required to maintain an ‘ATTENDANCE AND ASSESSMENT RECORD’ for every semester, which consists of attendance marked in each theory / Laboratory / Laboratory integrated Theory Courses/Employability Enhancement courses/ Audit Courses, the assessment marks and the record of class work (topics covered), separately for each course handled by the teacher. This should be submitted to the Head of the Department periodically (at least three times in a semester) to check the syllabus coverage and the records of assessment marks and attendance. The Head of the Department will affix his/her signature and date after due verification. At the end of the semester, the record should be verified by the Head of the Department who shall keep this document in safe custody (for five years). The records of attendance and assessment of both current and previous semesters should be available for inspection.

10.1. Assessment for Theory (T) Courses

For Theory Courses including mandatory courses out of 100 marks, the maximum marks for Continuous assessment is fixed as 40 and the End Semester Examination carries 60 marks. The End Semester Examination for theory courses including mandatory courses will be of 3 Hours duration and shall normally be conducted for a maximum of 100 marks between November /December during the Odd Semesters and between April/May during the Even Semesters. End semester Examination is mandatory requirement for passing the Course.

Continuous Assessment is based on the performance of the students in tests and tutorial or objective tests. Two assessments of equal weightage will be conducted by the Controller of Examinations. The total marks obtained in the assessments put together shall be reduced to 40 marks and rounded off to the nearest integer. In case a student misses the assessment due to medical reasons (hospitalization / accident / specific illness) or due to participation in the College / University / State / National / International level Sports events with prior permission from the HOD, a Re-assessment may be given at the end of the semester after getting approval from the Head of the Department through the concerned Course handling faculty.

To arrive the Continuous Assessment Mark, the following guidelines are to be followed.

Table 8 – Weightage for Continuous Assessment in Theory(T) courses

S.No.	Category Details	Marks
1	Assessment I	15
2	Assessment II	15
3	Other Co-curricular Activities such as Employability online Test/Mini Projects/ Scopus indexed publications/ Online MCQs/ Case studies/Tutorials/Innovative Projects idea generation/ Problem solving and Implementation etc.,	10
Total		40

10.2. Assessment for Laboratory integrated Theory(L/T) Courses

The maximum marks for Internal Assessment shall be 50 in case of theory courses with Laboratory component.

(i.e.) Each course shall be evaluated for a maximum of 100 marks as shown below:

Table 9 – Weightage for Continuous Assessment and End semester Examination in Laboratory integrated Theory courses

L	T	P	C	Continuous Assessments		End semester examination	
				Theory	Laboratory	Theory	Laboratory
1	0	1	1.5	50%	50%	----	----
1	0	2	2	25%	25%	----	50%
2	0	2	3	35%	15%	50%	----
1	0	4	3	15%	35%	----	50%
3	0	2	4	35%	15%	50%	----
2	0	4	4	25%	25%	40%	10%

The assessment of laboratory practical components will be based on turn-to-turn supervision of the student's work, performance in laboratory practical test.

10.3. Assessment for Laboratory(L) Courses

Each laboratory Courses shall be evaluated for a maximum of 100 marks. Every laboratory exercise / experiment shall be evaluated based on the student performance during the laboratory class and the student's record shall be maintained. The End Semester Examination will be conducted for 3 hours duration and shall normally be conducted for a maximum of 100 marks by Internal Examiner.

Table 10 – Weightage for Continuous Assessment and End semester Examination in Laboratory (L) courses

Sl. No	Description		Marks
1	Internal Assessment (100 Marks) *		60
	Evaluation of Laboratory Observation, Record	Laboratory Model examination	
	50	50	
	*Internal assessment shall be converted into 60 marks		
2	End Semester Practical Examinations conducted by Internal Examiner appointed by Controller of Examinations.		40
Total			100

Examination shall normally be conducted between October and December during the odd semesters and between April and June during the even semesters.

10.4. Assessment for Project Work

Project work may be allotted to a single student or to a group of students not exceeding 4 per group.

The Head of the department shall constitute a review committee for project work. There shall be three reviews during the semester by the review committee. The student shall make a presentation on the progress made by him / her before the committee. The marks obtained in the three reviews will be as indicated in **clause 10.4.1.**

Table 11 – Weightage for Continuous Assessment & End semester Examination for project work

Continuous Assessment (60 Marks) (By supervisor and Committee Members)			End semester Examination (40 Marks) (By Internal and External Examiner)			
Review I	Review II	Review III	Project Report Evaluation 20 marks		Viva-Voce 20 marks	
			Supervisor	External	Internal	External
10	25	25	10	10	10	10

10.4.1. The project work shall be evaluated for a maximum of 100 marks, of which continuous Assessments carry 60 marks and the End Semester Examination (Project report evaluation and Viva- Voce Examination) carries 40 marks. Internal and External Examiner will be appointed by Controller of Examinations The project report shall be submitted as per the approved guidelines. Marks are awarded to each student of the project group based on the individual performance in the project report evaluation and viva-voce examination.

10.4.2. If a student fails to submit the project report on or before the specified deadline, he/she is deemed to have failed in the Project Work and shall re-register for the same in a subsequent semester.

10.5. Assessment for Self-learning courses / Case Study/ Creative and Innovative project

The Self-learning courses / Case study / Creative and Innovative Project shall carry 100 marks and shall be evaluated through continuous assessment only. Every student is expected to present a minimum of one presentation / demonstration in the prescribed semester before the evaluation committee. The three-member committee consisting of one coordinator and two members appointed by the Head of the Department will evaluate the seminar and at the end of the semester, the marks can be consolidated and taken as the final mark. The evaluation shall be based on the following table

Table 12 – Weightage for Continuous Assessment for Self-Learning courses

Seminar Paper	Presentation	Viva-Voce	Total Marks
40	40	20	100

10.6. Assessment for Internship

The Internship shall carry 100 marks and shall be evaluated through continuous assessment only as per Table. At the end of the Industrial Training / Internship, the student shall submit a certificate from the organization where the student has undergone training and a brief report about the training. The evaluation will be made based on this report, presentation and a Viva-Voce Examination conducted internally by a three-member Departmental Committee consisting of one coordinator and two members constituted by the Head of the Department. Certificates (issued by the Organization) submitted by the student shall be attached to the mark list and sent to the Controller of Examinations by the Head of the Department.

Table 13 – Weightage for Continuous Assessment for Internship

Technical knowledge	External evaluation (by the Internship Provider)	Report evaluation	Presentation	Viva-voce	Total Marks
20	20	20	20	20	100

10.7. Assessment of the Industry Oriented Course

The evaluation of the Industry Oriented Courses is fully internal and shall be done by the course coordinator from the institution and the mentor from the firm. If the course involves certification from an identified firm/company, then 20% of the total marks will be included in the internal assessment marks, 30% will be included from the marks provided by the firm and 50% shall be evaluated by the respective Course Coordinators of the college by conducting appropriate theory and / or laboratory tests.

Table 14 – Weightage for Assessment for Industry Oriented Course

Category	Internal assessment marks	Firm	Course coordinators (theory and / or laboratory tests)
Certification	20%	30%	50%

10.8. Assessment for Value Added Course

- The one/two credit courses shall carry 100 marks and shall be evaluated through continuous assessments only.
- Two Assessments shall be conducted during the semester by the Department concerned.

- The total mark obtained in the tests shall be reduced to 100 marks and rounded to the nearest integer.
- The Head of the Department may identify a faculty member as coordinator for the course. A committee consisting of the Head of the Department, staff handling the course and a senior Faculty member nominated by the Head of the Department shall monitor the evaluation process.
- The grades shall be assigned to the students by the above committee based on their relative performance.
- The list of students along with the marks and the grades earned may be forwarded to the Controller of Examinations for appropriate action at least one month before the commencement of End Semester Examinations.

10.9. Assessment for Online Course

On successful completion of each online course, the student has to submit the copy of the certificate to the Head of the Department. The Head of the Department shall form a team of senior faculty members (preferably three) to recommend the credit and the grade that should be awarded to the student by appropriately mapping the score earned by the student as mentioned in clause 4.8.2. The results can be sent to the Controller of Examinations after the due approval by the Head of the Department. On successful completion of online courses adding to three credits, the student can obtain a waiver from doing either a Program Elective or an Open Elective.

11. PASSING REQUIREMENTS

- 11.1.** The passing requirement for a student in a course is determined based on the marks obtained both in continuous assessment and end semester examinations. A student, who secures not less than 50% of total marks prescribed for the course [continuous Internal Assessment + End semester Examinations] earns a minimum of 6 grade points in a course subject to secure a minimum of 45% marks in the end semester examinations, wherever applicable, shall be declared to have successfully passed the course.
- 11.2.** If a student fails to secure a pass in theory courses/ laboratory course in the current semester examination, he/she is allowed to write arrear examinations. The internal assessment marks obtained by the student in the first appearance shall be retained and considered valid for all subsequent attempts till the student secures a pass. However, from the third attempt onwards if a student fails to obtain pass marks (IA + End Semester Examination) as per clause 11.1, then the student shall be declared to have passed the examination if he/she secures a minimum of 50% marks prescribed for the end semester examinations alone.
- 11.3.** The passing requirement for the courses which are assessed only through purely internal assessments (EEC courses except project work), is 50% of the internal assessment (continuous assessment) marks only.

- 11.4.** If a candidate fails in the Creative innovative project (EEC course), he/she has to revise the Project Report within 30 days from the date of declaration of the results. The revised report is reassessed by subsequent viva-voce examination. It will be considered as reappearance with payment of exam fee. In case a student fails in the resubmission of the project report and the subsequent viva-voce examination, the student shall register for the course in the subsequent semester.
- 11.5.** Double valuation is adopted for all the theory courses in order to overcome any subjectivity in single valuation in the end semester examinations. So the provision for revaluation does not arise. The marks whichever is higher, that will be considered for final mark of the student.
- 11.6.** If the difference in the total marks awarded is greater than 15 between the first and second valuation, third valuation will be carried out. The highest marks awarded in the two valuations having difference less than 15 marks, will be the final mark. However, if a student wants to appeal for review of the result in any subjects, he / she can submit a challenge review application to COE office. A committee consisting of the Head of the Department, concerned faculty advisor and a subject expert (Internal / External) nominated by the Head of the Institution will review and give its recommendations to the Controller of Examinations.
- 11.7.** Supplementary Examinations
- 11.8.** If a student fails to secure a pass in theory course(s) of VIII semester examination, he/she is eligible to appear for a one-time Supplementary Examination which shall be conducted at the end of VIII semester, for the subjects of VIII semester alone within 30 days from the date of declaration of the results.

12. AWARD OF LETTER GRADES

The performance of a student will be reported using letter grades, absolute grading shall be followed for those students who passed the examination as per the passing requirements.

Table 16– Range of Marks for Absolute grading system

Letter Grade	S	A+	A	B+	B	C+	C	U
Range of total marks	91-100	81-90	71-80	66-70	61- 65	56 - 60	50 - 55	< 55
Grade point	10	9	8	7	6.5	6	5	0

Absolute grading method is adopted for all course categories.

For those students who have not passed “U” grade (re-appearance) shall be awarded.

‘AB’ denotes Absent

‘RA’ denotes Reappearance registration is required for that particular course.

‘SA’ denotes shortage of attendance (as per Clause 7) and hence prevented from writing end semester examination.

‘W’ indicates withdrawal from the course.

For the Co-curricular activities such as NCC / NSS / NSO / YRC, a satisfactory / not satisfactory grading will appear in the mark sheet. Every student shall put in a minimum of 75% attendance in the training and attend the camp compulsorily. The training and camp shall be completed during the first year of the programme. However, for valid reasons, the Head of the Institution may permit a student to complete this requirement in the second year. A satisfactory grade in the above co- curricular activities is compulsory for the award of degree. The grades S, A+, A, B+, B, C+, C, U obtained for the one/two credit course shall figure in the Mark sheet under the title ‘Value Added Courses’. The other grades RA, SA will not figure in the mark sheet.

13. GPA AND CGPA CALCULATION

After results are declared, Grade Sheets will be issued to each student which will contain the following details:

- The list of courses registered during the semester and the grades scored.
- The grade point average (GPA) for the semester
- The cumulative grade point average (CGPA) of all courses registered from first semester onwards.

During each semester, the list of courses registered, and the grades scored in each course are used to compute the Grade Point Average (GPA). GPA is the ratio of the sum of the products of the number of credits of courses registered and the grade points corresponding to the grades scored in those courses, taken for all the courses, to the sum of the number of credits of all the courses in the semester.

$$\text{GPA / CGPA} = \frac{\sum_{i=1}^n C_i GP_i}{\sum_{i=1}^n C_i}$$

Where, C_i - is the Credits assigned to the course

GP_i - is the grade point corresponding to the letter grade obtained for each course

n - is number of all Courses successfully cleared during the particular semester in the case of GPA and during all the semesters in the case of CGPA.

CGPA will be calculated in a similar manner, considering all the courses enrolled from first semester. “RA” and “SA” grades will be excluded for calculating GPA and CGPA.

The credits earned through one / two credit courses shall not be considered for calculating GPA and CGPA.

If a student study more number of electives (PEC/OEC) than required as per the student’s programme curriculum, the courses with higher grades alone will be considered for calculation of CGPA

14. ELIGIBILITY FOR THE AWARD OF DEGREE

A student shall be declared to be eligible for the award of the B.E. / B.Tech. Degree provided the student as

- i. Successfully gained the required number of total credits as specified in the curriculum corresponding to the student's programme within the stipulated time.
- ii. Successfully completed the course requirements, appeared for the End-Semester examinations and passed all the subjects prescribed in all the 8 semesters within a maximum period of 7 years reckoned from the commencement of the first semester to which the candidate was admitted.
- iii. Successfully passed any additional courses prescribed by the Board of Studies.
- iv. Successfully completed the NCC / NSS / NSO / YRC requirements.
- v. No disciplinary action is pending against the student.
- vi. The award of Degree must have been approved by the Syndicate of the University.

15. CLASSIFICATION OF THE DEGREE AWARDED

15.1. First Class with Distinction:

A student who satisfies the following conditions shall be declared to have passed the examination in First class with Distinction:

- Should have passed the examination in all the courses prescribed in the curriculum of the respective programme in the first appearance itself, which includes authorized break of study of one year. Withdrawal from examinations will not be considered as an appearance.
- Should have secured a CGPA of not less than 8.50.
- Should not have been prevented from writing end semester examination due to lack of attendance in any of the courses.

Table 17– Summary of procedure of Examination for B.E./B.Tech-First Class with Distinction

Degree (i)	Duration of programme (ii)	Duration permitted (iii)	Additional credits (iv)	CGPA (v)	Pass in (vi)	Break of study (vii)	Prevention to write end semester examination	Withdrawal from writing end semester examination (viii)
B.E./B.Tech. (Regular)	4 years	4 years	-	8.5	First attempt	One year authorised break of study included in the Duration permitted (ii)	Not permitted	Will not be considered as an attempt
B.E./B.Tech. Lateral Entry	3 years	3 years	-	8.5	First attempt	One year authorised break of study included in the Duration permitted (ii)	Not permitted	Will not be considered as an attempt
B.E./B.Tech. (Hons)	3/4 years (Lateral entry, Regular entry, respectively)	3/4 years (Lateral entry, Regular entry, respectively)	18 credits from more than one verticals of the same programme	8.5	First attempt	One year authorised break of study	Not permitted	Will not be considered as an attempt

	Regular respectively)					included in the Duration permitted (iii)		
B.E./B.Tech. Minor	3/4 years (Lateral entry, Regular respectively)	3/4 years (Lateral entry, Regular respectively)	18 credits from any one vertical of the other programme	8.5	First attempt	One year authorised break of study included in the Duration permitted (iii)	Not permitted	Will not be considered as an attempt

15.2. First Class:

A Student who satisfies the following conditions shall be declared to have passed the examination in First class:

- Should have passed the examination in all the courses prescribed in the curriculum of the respective programme in the first appearance itself, which includes authorized break of study of one year. Withdrawal from examinations will not be considered as an appearance.
- Should not have been prevented from writing end semester examination due to lack of attendance in any of the courses.

Table 18– Summary of procedure of Examination for B.E./B.Tech-First Class

Degree (i)	Duration of programme (ii)	Duration permitted (iii)	Additional credits (iv)	CGPA (v)	Pass in (vi)	Break of study (vii)	Prevention to write end semester examination	Withdrawal from writing end semester examination (viii)
B.E./B.Tech. (Regular)	4 years	5 years	-	6.5	-	One year authorised break of study included in the Duration permitted (iii)	Included in the Duration permitted (iii)	-
B.E./B.Tech. Lateral Entry	3 years	4 years	-	6.5	-	One year authorised break of study included in the Duration permitted (iii)	Included in the Duration permitted (iii)	
B.E./B.Tech. (Hons)	3/4 years (Lateral entry, Regular respectively)	4/5 years (Lateral entry, Regular respectively)	18 credits from more than one verticals of the same programme	6.5	First attempt	One year authorised break of study included in the Duration permitted (iii)	Not permitted	Will not be considered as an attempt
B.E./B.Tech. minor	3/4 years (Lateral entry, Regular respectively)	4/5 years (Lateral entry, Regular respectively)	18 credits from any one vertical of the other programme	6.5	-	One year authorised break of study included in the Duration permitted (iii)	Included in the Duration permitted (iii)	-

15.3. Second Class:

All other students (not covered in clauses 15.1 and 15.2) who qualify for the award of the degree (vide Clause 14) shall be declared to have passed the examination in Second Class.

A student who is absent in the End Semester Examination in a course / project work after having registered for the same shall be considered to have appeared in that examination (except approved withdrawal from end semester examinations as per clause 16) for the purpose of classification.

16. Attendance Criterion

- 1.1. The students are expected to attend all the classes without fail. Attendance of the student in each course is calculated from

$$\% \text{ of attendance} = \frac{\text{Actual No. of Classes attended}}{\text{Total No. of Classes conducted}} \times 100$$

- 1.2. The University mandates a minimum overall attendance of 80%. This overall attendance percentage is calculated by taking average of student's attendance in all the registered courses in a semester. For example, if a student has attendance of ATT1, ATT2, ATT3, ATT4, ATT5 and ATT6 in the registered Course 1, Course 2, Course 3, Course 4, Course 5 and Course 6, respectively in a semester, then overall attendance of such student's is calculated from

$$\% \text{ of Overall Attendance} = \frac{(\text{ATT1} + \text{ATT2} + \text{ATT3} + \text{ATT4} + \text{ATT5} + \text{ATT6})}{\text{Total No. of Classes conducted for 'SIX' courses}} \times 100$$

- 1.3. Marks will be awarded for student's attendance in 'EACH' course and the distribution of marks is given below;

Attendance (%)	80 – 85%	86 – 90%	91 – 95%	Above 95%
Marks	1	2	3	5

The marks earned by a student shall be included in the Continuous Assessment for each course, based on the percentage of attendance secured in a particular course as given above.

- 1.4. For medical reasons, if a student is not able to attend classes, 'Medical Certificate' shall be furnished to the Principal, within 5 days from the date of reporting back for class work. In the event of student not able to secure 80% attendance, but has at least 70% attendance, such 'Medical Certificate' shall be considered, with the approval of the Principal. In this case, the overall percentage of attendance in all the registered courses in a semester is calculated from clause 1.2 of this regulation with inclusion of 'number of periods during the medical emergency (MEP)' as below;

$$\% \text{ of Overall Attendance} = \frac{(\text{AP})}{\text{TP} - \text{MEP}} \times 100$$

The student shall be permitted to appear in the End Semester Examinations, if the overall attendance in each registered course is 75% and above.

- 1.5. Under any circumstances, medical certificate(s) submitted after the due date, as stipulated in Clause 11.4 shall not be accepted and in this case, % of attendance of the student is calculated as given in Clause 11.1.
- 1.6. The student shall be prevented from appearing in the end semester examination for all courses in a semester, if the overall attendance secured by a student is less than 80%. Such prevented student shall not be permitted to go to next semester. Importantly, such prevented student shall be permitted to rejoin the programme in the semester of prevention, during only in the next academic year and undergo all the courses. If the academic regulation is changed, addition / deletion of course(s) shall be prescribed by the Director, Centre for Academic Courses, and such student shall undergo additional courses, if any for completion of the programme.
- 1.7. The students should get prior approval from the respective Head of the Institution to attend campus recruitments, seminars, project works, internships, co-curricular and extra-curricular activities. Only upon prior approval of Head of the Institution, attendance for the above said activities shall be considered as 'ON-DUTY'. Students shall be permitted to avail only 10% of total working days in a semester. However, student participating in sports activities, representing the institution in the University / State / National / International Level, shall be permitted to avail ON-DUTY without any restriction period of 10%, only with prior approval of the Chairman, Anna University Sports Board, through the respective Head of the Institution. Additional classes shall be conducted by the Institute to the student(s) who are participating only in above said Sports activities so that such students shall attain the prescribed overall percentage attendance to appear in the End Semester Examinations.
- 1.8. The list of students eligible for appearing in the end semester examination(s) and prevented from writing the end semester examination(s) shall be published by the Controller of Examinations within THREE working days from the last working day of a particular semester.

A student, if eligible for appearing in the end semester examinations shall be allowed to withdraw the course(s) for bona fide reason(s), only with prior approval of the Head of the Institution and the same shall be intimated to the Director, Centre for Academic Courses. In case of medical emergencies alone, post-facto approval may be accorded with prior intimation received from the student or parent or guardian by the Head of the Institution. Students shall appear for the 'End Semester Examination' in the subsequent semester. The course(s) withdrawn shall not be considered as an appearance for classification of degree. For any course that may be withdrawn by the student in the final

semester of the programme, supplementary examination shall be conducted within a maximum period of 30 working days from the date of publication of the results.

17. PROVISION FOR WITHDRAWAL FROM EXAMINATION

A student may, for valid reasons, (medically unfit / unexpected family situations / sports approved by Head of the Institution, and HOD) be granted permission to withdraw from appearing for the end semester examination in any course or courses in anyone of the semester examinations during the entire duration of the degree programme. The application shall be sent to the Head of the Institution through the HOD with the required documents.

Withdrawal application shall be valid only if the student is otherwise eligible to write the examination (Clause 7) and if it is made within TEN working days before the commencement of the end semester examination in that course or courses and also recommended by the Head of the Department.

Notwithstanding the requirement of mandatory TEN working days' notice, applications for withdrawal for special cases under extraordinary conditions will be considered on the merit of the case.

If a student withdraws a course or courses from writing end semester examinations, he/she shall register the same in the subsequent semester and write the end semester examination(s).

Withdrawal shall not be considered as an appearance for deciding the eligibility of a student for First Class with Distinction.

Withdrawal is permitted for the end semester examinations in the final semester only if the period of study of the student concerned does not exceed 5 years with approval of Controller of Examinations.

18. BREAK OF STUDY FROM A PROGRAMME

A student is permitted to go on break of study for a fixed period of one year as a single break in the entire course of study.

When a student applies for break of study, the student shall apply to the Head of the Institution in advance. The application duly filled by the student shall be submitted through the Head of the Department.

The students permitted to rejoin the programme after break of study / prevention due to lack of attendance, shall be governed by the Curriculum and Regulations in force at the time of rejoining. The students rejoining in new Regulations shall apply to the Academic Council in the prescribed format through the Head of the Department at the beginning of the readmitted semester itself for prescribing additional/equivalent courses, if any, from any semester of the regulations in-force, so as to bridge the curriculum in-force and the old curriculum.

The total period for completion of the programme reckoned from the commencement of the first semester to which the student was admitted shall not exceed the maximum period specified in clause

5.1 irrespective of the period of break of study, in order that the student may be eligible for the award of the degree (**vide clause 14**).

In case there is any period of break of study more than the permitted duration of break of study, the student shall be permitted to continue the programme only if the approval is obtained from the Director of Technical Education /University through the Head of Institution before the end of the semester in which the student has taken break of study.

If a student has not reported to the department for a period of two consecutive semesters without any intimation, the name of the student shall be deleted permanently from the college enrollment. Such students are not entitled to seek readmission under any circumstances.

19. PROCEDURE FOR USING SCRIBE

If a candidate is physically handicapped (in case of accidents / ill health) at the time of examination, He / she may be permitted to use a scribe to write the examination. In such case 30 minutes extra time will be permitted for continuous assessment test and 60 minutes for end semester examination. The Scribe shall be a non-engineering student / graduate.

20. DISCIPLINE

Every student is required to observe disciplined and decorous behavior both inside and outside the college and not to indulge in any activity which will tend to bring down the prestige of the institution.

In the event of an act of indiscipline being reported, the Head of the Institution shall constitute a disciplinary committee to enquire into act of indiscipline.

The Head of the Institution shall constitute a disciplinary committee consisting of the Head of the department to which the student concerned belongs, and the Heads of other department to enquire into acts of indiscipline and notify the Head of the institution about the disciplinary action recommended for approval. In case of any serious disciplinary action which leads to suspension or dismissal, then a committee shall be constituted by the Head of the Institution for taking a final decision. If a student indulges in malpractice in any of the examinations, the student shall be liable for punitive action as prescribed by the institution from time to time.

21. Academic Audit

The Head of the Department shall arrange to conduct the Academic Audit once in every year for all the courses conducted in the respective semesters through external expert(s) approved by the Head of the Institution.

Academic audit shall cover (not limited to),

- 21.1.** Course delivery and adherence to the course plan, syllabus coverage, quality of question papers used for continuous assessments, end semester examinations, maintenance of laboratory experimental set ups and equipment, practical assignments, mini projects and conduct of practical classes and their evaluation.
- 21.2.** Co-curricular and extracurricular activities available for students, the monitoring mechanism of activity points to be earned by the students.
- 21.3.** Academic functioning of the Department encompassing students, faculty and administration covering punctuality, attendance, discipline, academic environment, learning ecosystem, academic achievements and benchmarking. The quality criteria prescribed by statutory bodies.
- 21.4.** Academic documents of UG programmes for a particular batch of students shall be kept in the respective department for a period of TWO years after the end of programme duration.

22. REVISION OF REGULATIONS, CURRICULUM AND SYLLABI

The Academic council of the college reserves the right to revise or change or amend the regulations, the scheme of examinations, the curriculum and the syllabi from time to time if found necessary.